



# Swap Headers

Big Block Chevy, Swept Back Design,  
1st Generation Camaro with  
Detroit Speed Sub Frame



- Patented design (U.S. Patent US D700,554 S)
- Tight radius elbows places the 321 Stainless tubes tight to the block
- Rear dump header design positions the tubes away from steering shafts, frame rails
- Tube diameter -- 1-7/8" with 3" collectors
- Fits standard or raised port heads
- Eye-appealing header flanges and the collector flange further enhance any engine compartment's eye appeal
- Package includes everything needed for the installation -- headers, ARP 12-point Stainless Steel bolts & washers and Mr. Gasket MLS (Multi Layer Stainless) header

## Part Numbers, Specs, Pricing

Applications:

- Big Block Chevy, Swept Back Design
- 1st Gen Camaro with Detroit Speed Sub Frame

Part Number	Tube Diameter	Tube Gauge	Finish	List Price
301011	1-7/8"	18 gauge	Mill	\$1,195.00
301012	1-7/8"	18 gauge	Satin	\$1,395.00
301013	1-7/8"	18 gauge	Mirror Polish	\$1,595.00
301014	1-7/8"	18 gauge	Ceramic Coated Silver	\$1,495.00
301015	1-7/8"	18 gauge	Ceramic Coated Black	\$1,495.00

## Dimensions

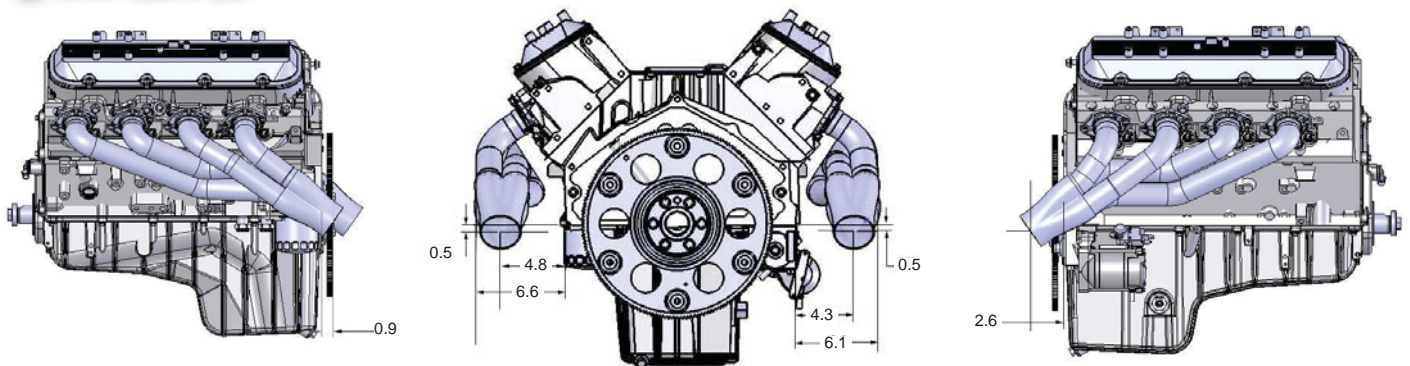

## Finishes



Mill



Satin



Mirror  
Polish



Ceramic  
Coated  
Silver



Ceramic  
Coated  
Black