



# Swap Headers

GM LS Engines, Center Exit 1932 Ford & Similar Narrow Chassis



**IMAGE COMING SOON!**



- Patented design (U.S. Patent US D700,554 S)
- We highly recommend the use of our Extreme Low Profile Clamps to add to the end of the collector

## Part Numbers, Specs, Pricing

Applications - LS Engines into:

- 1932 Ford & Similar Narrow Chassis

| Part Number | Tube Diameter | Tube Gauge | Finish                | List Price |
|-------------|---------------|------------|-----------------------|------------|
| 101041      | 1-7/8"        | 18 gauge   | Mill                  | \$1,049.00 |
| 101042      | 1-7/8"        | 18 gauge   | Satin                 | \$1,249.00 |
| 101043      | 1-7/8"        | 18 gauge   | Mirror Polish         | \$1,449.00 |
| 101044      | 1-7/8"        | 18 gauge   | Ceramic Coated Silver | \$1,290.00 |
| 101045      | 1-7/8"        | 18 gauge   | Ceramic Coated Black  | \$1,290.00 |

## Dimensions

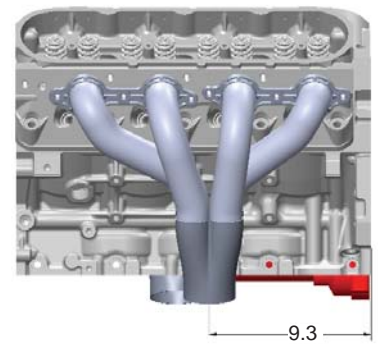
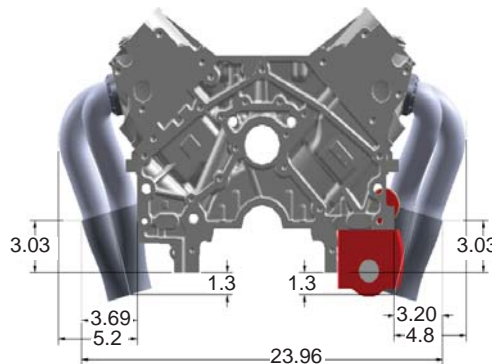
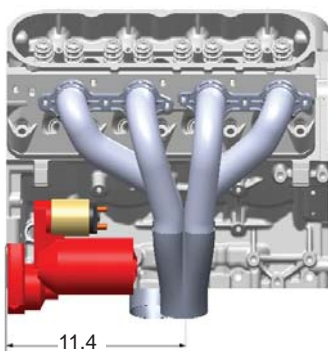

## Finishes



Mill



Satin



Mirror  
Polish



Ceramic  
Coated  
Silver



Ceramic  
Coated  
Black