



Swap Headers

GM LS Engines, Version II 1st Gen Camaro with Factory Sub-Frame & Steering Box



- Patented design (U.S. Patent US D700,554 S)
- Includes premium corrosion and heat-resistant ARP (Automotive Racing Products) 12-point, 300 grade stainless steel bolts and washers
- Large (1-7/8") 321 Stainless Steel header tubes
- Header tubes are mounted high and tight, makes a very compact, space efficient package
- Package includes everything needed for the installation -- headers, ARP 12-point Stainless Steel bolts & washers and Cometc MLS (Multi Layer Stainless) header

Part Numbers, Specs, Pricing

Applications:

- 1st Gen F-Body with stock subframe and steering box
- '70 - '81 F-Body
- '62 - '67 X-Body

Part Number	Tube Diameter	Tube Gauge	Finish	List Price
101021	1-7/8"	18 gauge	Mill	\$1,049.00
101022	1-7/8"	18 gauge	Satin	\$1,372.00
101023	1-7/8"	18 gauge	Mirror Polish	\$1,449.00
101024	1-7/8"	18 gauge	Ceramic Coated Silver	\$1,349.00
101025	1-7/8"	18 gauge	Ceramic Coated Black	\$1,349.00

Dimensions

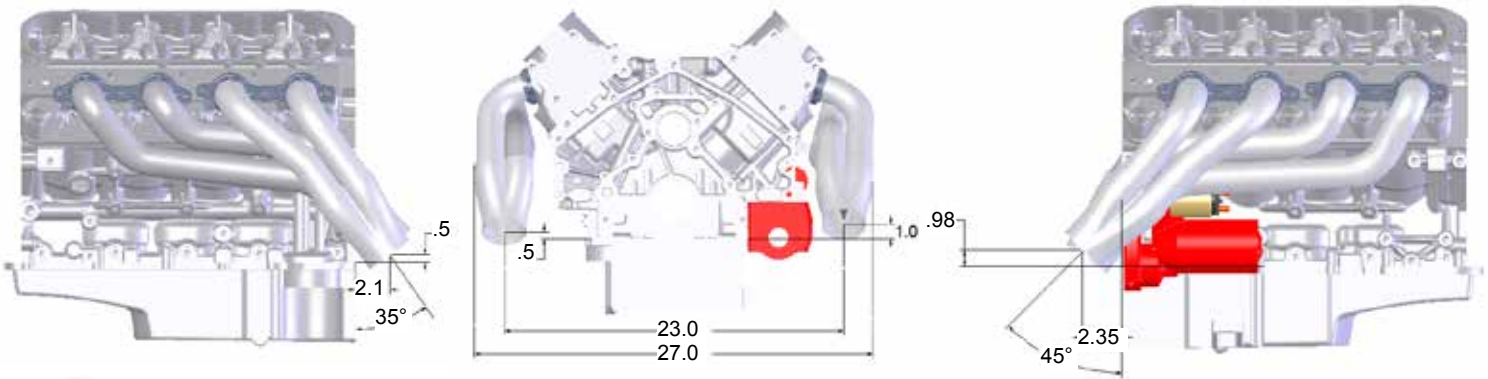

Finishes



As Cast Flange/
Mill Finish
on Tubing



Satin Flange/
Satin Finish
on Tubing



Mirror Polished Flange/
Mirror Polished
on Tubing



Mirror Polished Flange/
Silver Ceramic
on Tubing



Mirror Polished Flange/
Black Ceramic
on Tubing